

INSTALLATION INSTRUCTIONS: 5642

Early Bronco Dual Sport Heim Steering System 2.0

CONTENTS:

1 Tie Rod A	2 Castle Nut J 30-50 ft. lbs.
1 Drag Link B	1 3/4 Rod End Female with Tapered Stud K
2 Adjustment Bars C	1 Tapered Bushing L
4 3/4-16 Jam Nuts RHT D 125 ft. lbs.	1 Small Bottle Loctite Red M
2 3/4-16 Jam Nuts LHT E 125 ft. lbs.	1 1-3/4" Male Rod End with Tapered Stud N
1 3/4 Rod Ends Male RHT F	1 9/16" SAE Washer O
1 3/4 Rod End Female LHT G	
2 Small Cotter Pin 7/64 x 1.5 H	
1 3/4-16 Stover Lock Nut I 125-315 ft lbs.	

Knuckle Mounting Kits:

- 564X - 3/4" Bolts **282 ft. lbs.**
- 5647 - Tie Rod Under (TRU) Tapered Heim Stud Kit GM 1-Ton/F-150 Knuckle **60-75 ft. lbs.**
- 5648 - Tie Rod Under (TRU) Tapered Heim Stud Kit Early Bronco Knuckle **60-75 ft. lbs.**
- 5660/5661 - No Drill Hardware Kit

NOTE: If you cannot reach the specified torque setting, get the nut as tight as possible and stop before damaging the edges of the nut/bolt where the wrench makes contact. Always recheck hardware after driving Bronco off road and the first 100 miles. Then at every oil change. Mark the nuts with a paint pen to track any movement for a quick visual reference.

BEFORE STARTING PLEASE READ INSTRUCTIONS AND IDENTIFY ALL PARTS/HARDWARE ARE PRESENT.

Important: It is critical that the pitman arm does not leave center when installing this system, failure to do so will result in loss of turning radius and/or other steering issues. You will also want to make sure the tie rod tapered hole large side is pointed forward on the vehicle. The tapered hole can be rotated up or down to correct geometry. Before installing inspect all front end bushings for wear and tear as well as your ball joints. These items can affect your alignment and the overall driveability of the Bronco.

Notes: This system is only compatible with Early Broncos that have a factory style frame, steering box and front axle.

With Hellwig sway bars we recommend you use our Dual Sport Lower Coil Retainers (#5121)

Optional: Hardware piece **I** is to be used at the original track bar bolt location, once installed and torqued, cut the original bolt flush with the nut, or you may have interference with your new heim steer.

1. Chock the front and rear of one or both rear wheels, raise the front of the vehicle and set the front axle housing on jack stands.

2. If you're starting with a factory tie rod in known good condition, use this as a starting point to measure your toe in. Straighten the front wheels and measure the front and rear of the front tires side to side to calculate what your current toe in measurement is. At this time you will also verify that your pitman arm is centered on your steering gear box. For information on how to center your pitman arm follow this link: <https://youtu.be/LlhUaoE4zBo>

Note: Your toe in should be 1/8" for 35" and smaller tires. Larger tires may require up to a 1/16" inch more of toe in. Front of Tire Measurement: _____ Rear of Tire Measurement: _____

3. If you're starting with a factory tie rod in known good condition that has been aligned correctly. Measure your tie rod length, from center of tie rod end to end. You will use this measurement to setup the new heim steer tie rod so your toe in alignment is close. Record the measurement. Old Tie Rod Length

Measurement: _____

3a. Remove existing steering linkage off of the Bronco.



865.938.6696 www.dufftuff.com
6609 Bronco Ln.
Knoxville, TN 37921
1/3 06/25

TOOLS NEEDED:

- Floor Jack
- Jack Stands
- 3/8" Drive Torque Wrench
- 1/2" Drive Sockets and Wrench Set 1/2" -1 1/8"
- 3/8" Drive Sockets
- 1/2" Drive Socket -1 1/8"
- Crescent Wrench

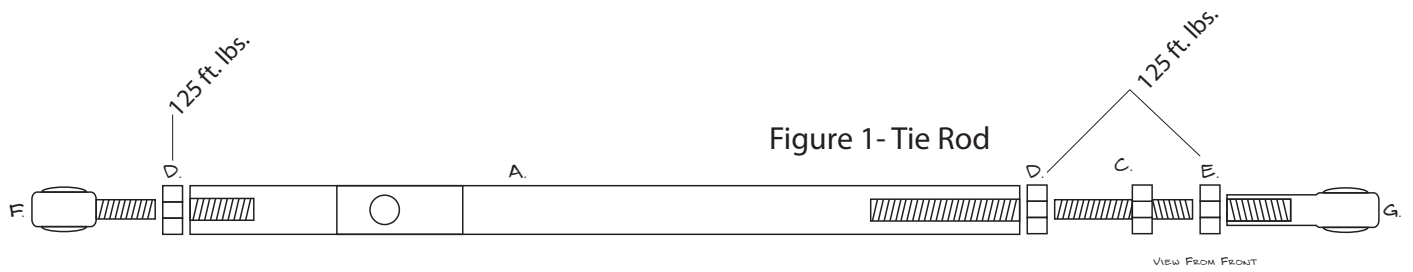

4. Before proceeding, go to the instructions included with the knuckle mounting hardware you chose for your system for proper configuration. If you purchased the 3/4" hardware kit (564X) you must drill your knuckles to 3/4". If you do not want to drill your knuckles and are installing the tapered heim studs tie rod under (TRU) then you can proceed with installing the tapered heim stud kit. (5647/5648). Do not drill your pitman arm. This system includes a tapered heim joint for the pitman arm. If yours is already drilled we recommend you replace it as this system is designed to use a pitman arm with a tapered hole. (#5472/5473/5474/5476)

5. With your knuckles drilled (or your TRU hardware bolted in place) assemble the tie rod bar as shown in **Figure 1**.

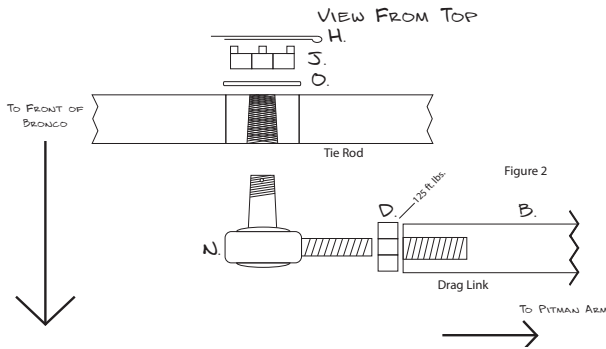

If you are using '66-'75 knuckles, the adjustment bar will be threaded almost entirely in. Follow your tie rod length measurement from step 3 to get the tie rod as close as possible.

With your measurement close, leave all hardware loose and attach to your knuckles.

IMPORTANT: Be sure that G & K only has 1/4" inch or less of threads exposed once the bar is installed & 100% aligned.

6. Using the appropriate diagram included with your hardware mounting kit, install the linkage tie rod under (TRU).

7. With the tie rod installed (all connections except at the knuckles themselves still loose). Locate drag link bar **B**, and assemble it as shown in **Figures 2 and 3**. (7/64" Pin **H**, is meant for the tapered heim end at the ends of the drag link.) Before installing the drag link to the tie rod and the pitman arm you will need to measure the distance from the saddle connection at the tie rod to the connection point at the pitman arm. Use this measurement to shorten or lengthen the drag link to the correct length. Be sure to read the info below before installing.

Note: Tapered bushing **L** is only used if you have a large taper ('67-75) Bronco Pitman arm.

8. Double check your measurements for toe in and verify your pitman arm is centered. Proceed with tightening all hardware.

9. A professional alignment is required after the installation of this system.

10. We provide red loctite as an added safety precaution. Only apply red loctite **M** after your alignment is done only where jam nuts **D & E** are located. You will need to loosen these jam nuts to expose the threads next to bar **A & B** then apply it and re-tighten the jam nuts. Only apply 2 to 3 drops of red loctite and do not use it if you plan on removing the steering system anytime soon. You can also ask your alignment technician to do this while performing the final alignment.

12. We recommend using a paint marker to mark all threaded connections. This will expose any potential

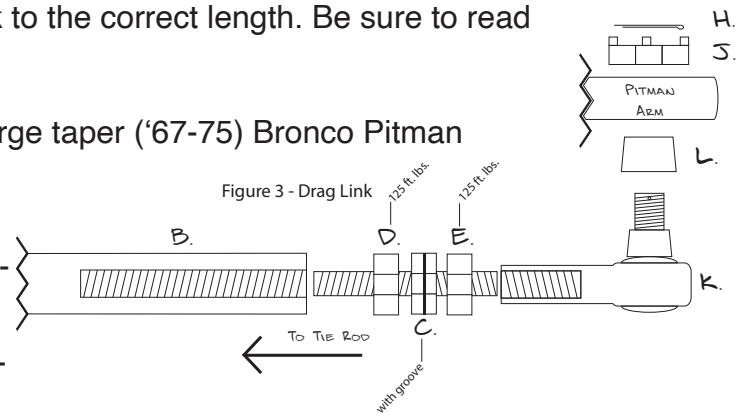

loose connections. Inspect all threaded connecting points after the first 100 miles, after every off-road event, and every oil change after installing.

Monster Mike's Tech Tip: You just installed the latest and greatest heim steer system for your Early Bronco and you probably think you are done right? Well let me introduce you to the bump steer eliminator 2.0 system. Although this new dual sport heim steer system prevents any added bump steer, the bump steer eliminator also reduces the normal bump steer that comes with every '66-77 Bronco. Looking for the most controlled ride at any speed and the ultimate confidence behind the wheel? Since you already have the steering system installed. We recommend pairing the dual sport heim steering with a Trac Bar Riser Bracket #5406 and our HD Hassle Free Trac Bar #5417/5418. When these parts are combined it will take a majority of the stress off of the frame and eliminate all sources that could introduce bump steer on your Early Bronco. **Note: If you are installing the bump steer eliminator, the dual sport steering system will need to be mounted above the knuckle (TRO).**

Add-ons to consider:



Drill Kit #5640-DK



Low Profile C-Cap Shock Mount #5640-C-Cap



Trac Bar Riser Bracket #5406



Tapered Heim Stud Kit #5647/5648



Hassle Free Trac Bar #5417/5418



1.5" Performance Package - 5061



Dual Sport Monster 4-Link Suspension System



Dual Sport Lower Coil Retainers #5121

LIMITED WARRANTY

James Duff Inc. warrants our products to the original purchaser to be free from defects in materials and workmanship. Warranty periods begin at the date of purchase and varies by product. Shocks have a limited lifetime warranty. Headers, Radiators and Suspension Products, Power Brake Boosters and Master Cylinders have a one year warranty. Adapters and soft goods such as upholstery, vinyl and rubber products have a 90 day warranty. All warranties are to the original purchaser with proof of purchase only. Such obligations under this warranty shall be limited to the repair or replacement, at JDI's discretion, of any assembly or part which upon examination by JDI proves to be defective. Any costs of removal, installation, re-installation or freight charges are expressly excluded from this warranty. This warranty covers only manufacturers defects, and does not cover product finish or damage resulting from abuse, misuse, negligence, racing, alteration, accident or damage in transit. All returns must be pre-authorized by JDI and accompanied with a Return Goods Authorization Number (RGA) and a dated proof of purchase. Returns must be made within 90 days of purchase, packaged sufficiently to prevent damage in shipment and sent prepaid to JDI, 6609 Bronco Lane, Knoxville, TN 37921. Returns without an RGA# will be refused. This warranty is expressly in lieu of all other warranties, expressed or implied, including the implied warranties of merchantability and fitness for use. This warranty gives you specific legal rights including other rights that vary from state to state. Some states do not allow limitations on how long an implied warranty lasts, or do not allow the exclusion of limitation of incidental or consequential damages, so the above limitations and/or exclusions may not apply to you.