

**INSTALLATION INSTRUCTIONS: 5660/5661**

**Heim Steering Hardware**

**CONTENTS:**

- 2 - Tapered Sleeves
- 2 - Shouldered Spacers
- 2 - Cotter Pins
- 2 - Delrin Heim Spacers
- 2 - 9/16" Unitorque Nuts
- 4 - 9/16" SAE Flat Washers
- 2 - 9/16" Grade 8 Bolts



865.938.6696 www.dufftuff.com  
 6609 Bronco Ln.  
 Knoxville, TN 37921  
 07/25

EXPLODED VIEW NOT TO SCALE

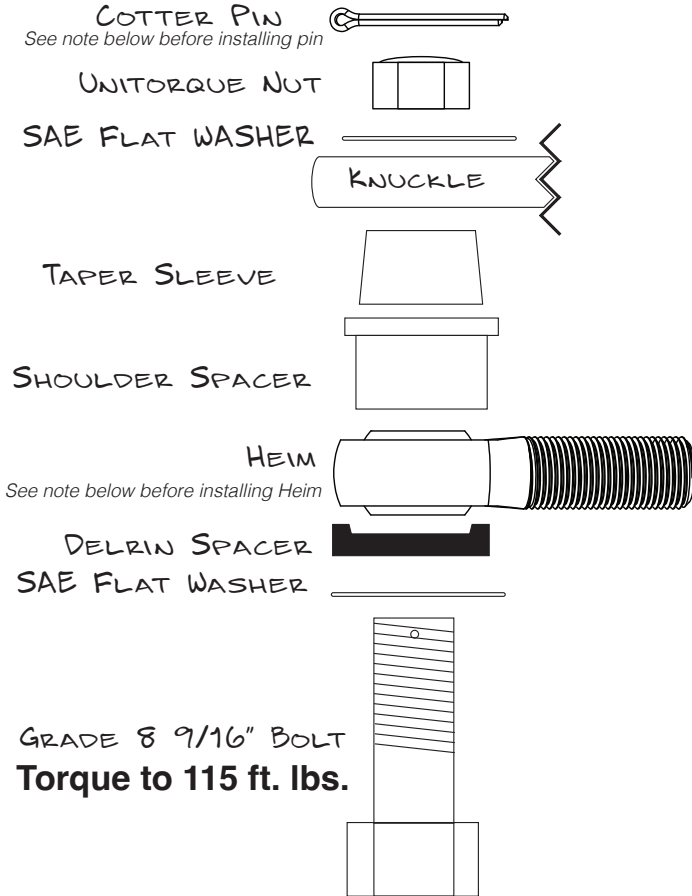

**Tie Rod Under (TRU)**

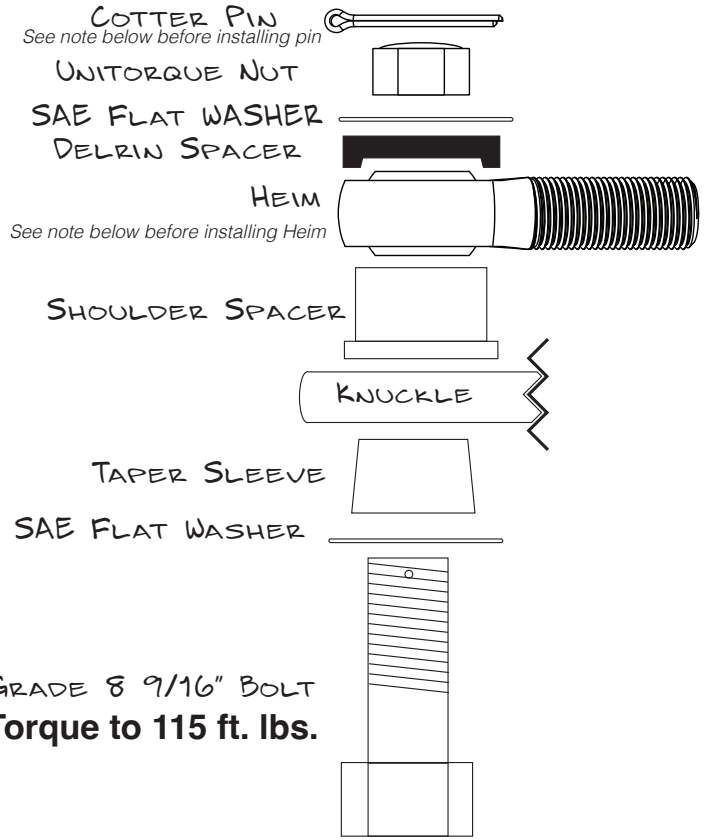

**Tie Rod Over (TRO)**

When installed, the tapered sleeve should not protrude more than 3/16" out of the knuckle. If the tapered sleeve protrudes too far, consider using a 7 degree tapered reamer to remove material. Part # 6171 on dufftuff.com

If the tapered sleeve does not protrude at least 1/32" from the knuckle, consider drilling the knuckle out to 3/4" and using tapered inserts. Like, part # 3735 on dufftuff.com

**\*Notes: Cotter pins are used as a secondary retainer if the nut were to loosen up. There is a short side and long side of the heim joint. The short side has a red teflon spacer between the body of the heim and the spherical ball. Install the short side against the delrin spacer.**

**If your Early Bronco Knuckle has been drilled to 3/4" previously or you are using James Duff Disc Brake Knuckles you must use the 564x tie rod to knuckle bolt kit.**

**LIMITED WARRANTY**

James Duff Inc. warrants our products to the original purchaser to be free from defects in materials and workmanship. Warranty periods begin at the date of purchase and varies by product. Shocks have a limited lifetime warranty. Headers, Radiators and Suspension Products, Power Brake Boosters and Master Cylinders have a one year warranty. Adapters and soft goods such as upholstery, vinyl and rubber products have a 90 day warranty. All warranties are to the original purchaser with proof of purchase only. Such obligations under this warranty shall be limited to the repair or replacement, at JDI's discretion, of any assembly or part which upon examination by JDI proves to be defective. Any costs of removal, installation, re-installation or freight charges are expressly excluded from this warranty. This warranty covers only manufacturers defects, and does not cover product finish or damage resulting from abuse, misuse, negligence, racing, alteration, accident or damage in transit. All returns must be pre-authorized by JDI and accompanied with a Return Goods Authorization Number (RGA) and a dated proof of purchase. Returns must be made within 90 days of purchase, packaged sufficiently to prevent damage in shipment and sent prepaid to JDI, 6609 Bronco Lane, Knoxville, TN 37921 Returns without an RGA# will be refused. This warranty is expressly in lieu of all other warranties, expressed or implied, including the implied warranties of merchantability and fitness for use. This warranty gives you specific legal rights including other rights that vary from state to state. Some states do not allow limitations on how long an implied warranty lasts, or do not allow the exclusion of limitation of incidental or consequential damages, so the above limitations and/or exclusions may not apply to you.